

Instructions for use



CE
0297



Straight handpiece RC-43
Contra-angle handpiece RC-56/ RC-58

Contents

Symbols	4
in the Instructions for use	4
on the medical device/packaging	5
1. Introduction	6
2. Safety notes	10
3. Product description	13
Straight and contra-angle handpiece	13
4. Operation	14
To change rotary instruments	16
Test run	19
5. Hygiene and maintenance	20
General notes.....	20
Limitations on processing	22
Initial treatment at the point of use	23

Manual cleaning	24
Manual disinfection	26
Drying	27
Inspection, Maintenance and Testing	28
Packaging	32
Sterilization.....	33
Storage.....	35
6. Accessories, consumables, spare parts and other recommended medical devices by W&H.....	37
7. Technical data	40
8. Disposal.....	42
Explanation of warranty terms	43
Authorized W&H service partners.....	45



WARNING!
(risk of injury)



ATTENTION!
(to prevent
damage occurring)



General explanations,
without risk to
persons or objects



Do not dispose of
with domestic waste

Symbols

on the medical device/packaging

 CE marking
with identification number
of the Notified Body

 DataMatrix Code
for product information
including UDI (Unique
Device Identification)

 HIBC Data structure in
accordance with
Health Industry Bar Code

 REF Catalogue number

 135°C
Sterilizable up to the
stated temperature

 Consult Instructions for use

 SN Serial number

 MD Medical Device

 UL Component Recognition
Mark indicates compliance
with Canadian and U.S.
requirements

 Date of manufacture

 **Rx**_{only} Caution! Federal law restricts this device to sale by or on the order of a dentist, physician, veterinarian or with the descriptive designation of any other practitioner licensed by the law of the State in which the practitioner practices to use or order the use of the device.

 Manufacturer

1. Introduction

Customer satisfaction has absolute priority in the W&H quality policy. This medical device has been developed, manufactured and subjected to final inspection according to legal regulations, quality and industry standards.

For your safety and the safety of your patients

Prior to initial use please read the Instructions for use. These explain how to use your medical device and guarantee a smooth and efficient operation.



Observe the safety notes.

Intended use

The dental handpiece/contra-angle is intended for the following applications: Removal of decayed materials, cavities and crown preparation, removal of fillings, finishing and polishing of tooth and restoration surfaces.

 Misuse may damage the medical device and hence cause risks and hazards for patient, user and third parties.



Qualifications of the user

We have based our development and design of the medical device on the dentists, dental hygienists, dental employees (prophylaxis) and dental assistants target group.

Responsibility of the manufacturer

The manufacturer can only accept responsibility for the safety, reliability and performance of the medical device when it is used in compliance with the following directions:

- > The medical device must be used in accordance with these Instructions for use.
- > The medical device has no components that can be repaired by the user.
- > Only the components approved by the manufacturer may be replaced (spray connection ring, sprayclip, O-ring, coolant hose).



Skilled application

The medical device is intended only for skilled application according to the intended use as well as in compliance with the valid health and safety at work regulations, the valid accident prevention regulations and in compliance with these Instructions for use.

The medical device should be prepared for use and maintained by staff who have been trained in procedures for infection control, personal safety and patient safety.

Improper use, (e.g., through poor hygiene and maintenance), non-compliance with our instructions or the use of accessories and spare parts which are not approved by W&H, invalidates all claims under warranty and any other claims.



Any serious incident that has occurred in relation to the medical device should be reported to the manufacturer and the competent authority!

2. Safety notes



- > Always ensure the correct operating conditions and cooling function.
- > Always ensure that sufficient and adequate cooling is delivered and ensure adequate suction.
- > In case of coolant supply failure, the medical device must be stopped immediately.
- > Use only filtered, oil-free and cooled air supplied by dental compressors to operate the medical device.
- > Check the medical device for damage and loose parts each time before using (e.g., push-button).
- > Do not operate the medical device if it is damaged.
- > Perform a test run each time before using.
- > Avoid overheating at the treatment site.
- > Do not lift the cheek or tongue with the medical device. Risk of burning due to the push-button heating up!
- > Do not touch the soft tissue with the head of the medical device. Risk of burning if the medical device overheats!
- > It is imperative to comply with the concentrations and exposure times specified by the manufacturer of the treatment water decontamination system, as well as its handling.



- > Before using the medical device for the first time, store it at room temperature for 24 hours.
- > The operation of the medical device is permitted only on supply units which correspond to the standards IEC 60601-1 (EN 60601-1) and IEC 60601-1-2 (EN 60601-1-2).

Hygiene and maintenance prior to initial use



- > The medical device is not sterilized when delivered.
- > The packaging is non-sterilizable.



- > Clean, disinfect and lubricate the medical device.
- > Sterilize the medical device.

3. Product description

Straight and contra-angle handpiece

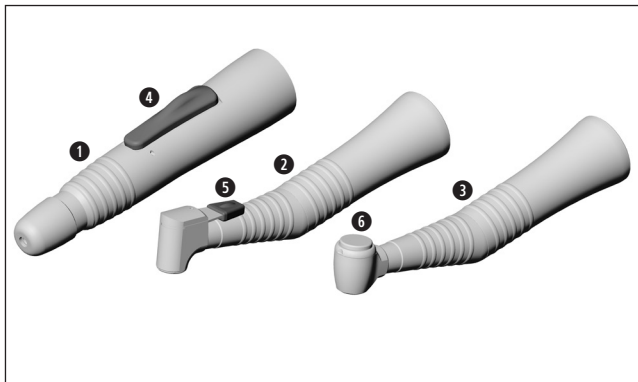

- ① RC-43
- ② RC-58
- ③ RC-56
- ④ Chuck lever
- ⑤ Latch
- ⑥ Push-button

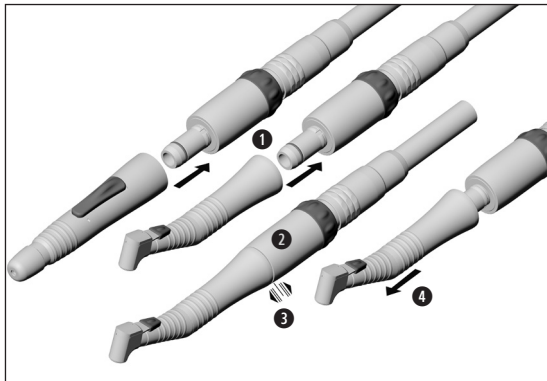

Do not assemble or remove the medical device during operation!

- 1 Push the medical device onto the motor until it engages audibly. 2



- 3 Verify full engagement

or

- 4 Remove the medical device.

Rotary instruments



- > Use only rotary instruments which are in perfect condition. Follow the operating instructions of the manufacturer.
- > Insert the rotary instrument only when the medical device is stationary.
- > Never touch the rotary instrument while it is still rotating.
- > Do not activate the chucking system of the medical device during operation. This leads to detachment of the rotary instrument, damage to the chucking system and/or heating up of the medical device. Risk of burning!

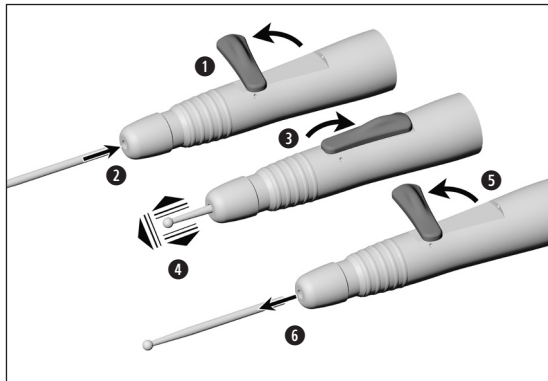

RC-43

- 1 Open the chuck lever.
- 2 Insert the rotary instrument up to the limit stop.
- 3 Close the chuck lever.



- 4 Verify full engagement.

- 5 Open the chuck lever and remove the rotary instrument 6.
Close the chuck lever.

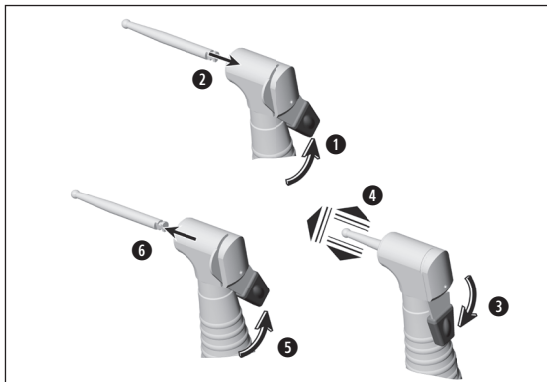

RC-58

- ❶ Open the latch.
- ❷ Insert the rotary instrument up to the limit stop and turn until it engages.
- ❸ Close the latch.



- ❹ Verify full engagement.

- ❺ Open the latch and remove the rotary instrument ❻. Close the latch.

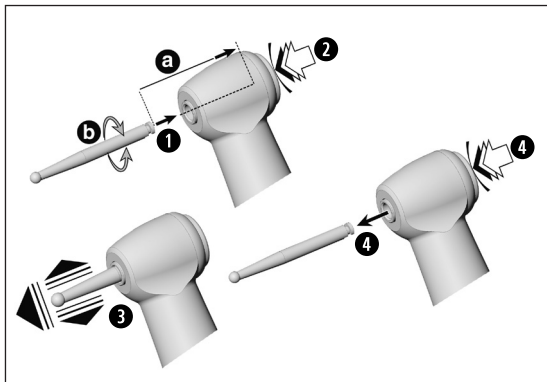

RC-56

- 1** Insert the rotary instrument until back stop [a].
- 2** Activate the push-button and turn the rotary instrument until it engages [b].



- 3** Verify full engagement

or

- 4** Activate the push-button and remove the rotary instrument.

Test run





Do not hold the medical device at eye level.

- > Insert the rotary instrument.
- > Operate the medical device.



In the event of operating malfunctions (e.g., vibrations, unusual noise, overheating, coolant failure or leakage) **stop the medical device immediately** and contact an authorized W&H service partner.

-  Follow your local and national laws, directives, standards and guidelines for cleaning, disinfection and sterilization.

-  The information on the validated reprocessing methods serves as an example for an ISO 17664 compliant reprocessing of the medical device.

-  > Wear protective clothing, safety glasses, face mask and gloves.

-  > Use only oil-free, filtered compressed air with a maximum operating pressure of 3 bar (43.5 psi) for manual drying.

Cleaning agents and disinfectants



- > Read the notes, follow the instructions and heed the warnings provided by the manufacturers of cleaning agents and/or disinfectants.
- > Use only detergents which are intended for cleaning and/or disinfecting medical devices made of metal and plastic.
- > It is imperative to comply with the concentrations and exposure times specified by the manufacturer of the disinfectant.
- > Use disinfectants which have been tested and found effective by, for example: the Verbund für Angewandte Hygiene e.V. (VAH = Association for Applied Hygiene), the Österreichischen Gesellschaft für Hygiene, Mikrobiologie und Präventivmedizin (ÖGHMP = Austrian Society for Hygiene, Microbiology and Preventive Medicine), the Food and Drug Administration (FDA) or the U.S. Environmental Protection Agency (EPA).



The user is responsible for validating its process if the specified cleaning agents and disinfectants are not available.



The product lifetime and the medical device's ability to operate correctly are mainly determined by mechanical stress during use and chemical influences due to processing.

- > Decommission worn or damaged medical devices and/or medical devices with material changes.

Processing cycles



- > Safe use is guaranteed until at least 1,000 reprocessing cycles.



Clean the medical device immediately after every treatment, to flush out any liquid (e.g., blood, saliva etc.) and to prevent settling on the internal parts.

- > Operate the medical device for at least 10 seconds at idle speed.
- > Ensure that all coolant outlets are rinsed out.



- > Wipe the entire surface of the medical device with disinfectant.
- > Remove the rotary instrument.
- > Remove the medical device.



Note that the disinfectant used during pre-treatment is only for personal protection and cannot replace the disinfectant step after cleaning.



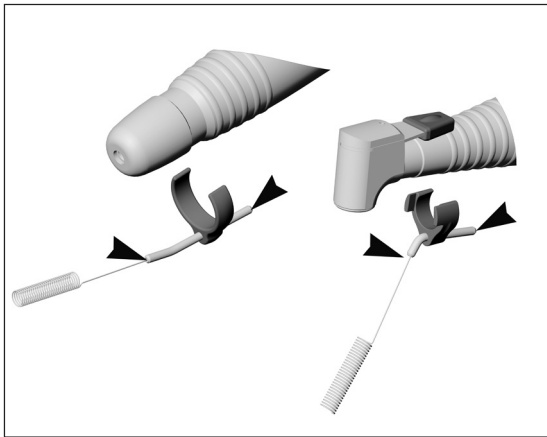

Do not place the medical device in liquid disinfectant or in an ultrasonic bath.

- > Clean the medical device under running tap water (< 35°C / < 95°F).
- > Rinse and brush off all internal and external surfaces.
- > Move moving parts back and forth several times.
- > Remove any liquid residues using compressed air.
- > When using the external coolant supply, remove the spray clip and the coolant hose.



Cleaning the external coolant tubes

Clean coolant outlets carefully with the nozzle cleaner to remove dirt and deposits.

-  Clean and disinfect the nozzle cleaner in an ultrasonic bath/disinfection bath.
-  If it proves impossible to correct the malfunction, please contact an authorized W&H service partner.

-  W&H recommends wiping down with disinfectant.

-  Evidence of the medical device's basic suitability for effective manual disinfection was provided by an independent test laboratory using the disinfectants “mikrozid® AF wipes” (Schülke & Mayr GmbH, Norderstedt) and “CaviWipes™” (Metrex).



- > Ensure that the medical device is completely dry internally and externally after cleaning and disinfection.
- > Remove liquid residues using compressed air.

Inspection



- > Check the medical device after cleaning and disinfection for damage, visible residual soiling and surface changes.
- > Reprocess any medical devices that are still soiled.
- > Sterilize the medical device following cleaning, disinfection and lubrication.

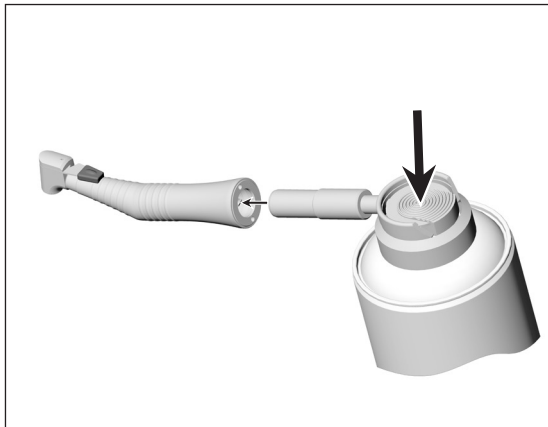

Lubrication



- > Lubricate the dry medical device immediately after cleaning and/or disinfection.

Recommended lubrication cycles

- > Essential after every internal cleaning
 - > Before each sterilization
- or
- > After 30 minutes of use or once a day

With W&H Service Oil F1, MD-400

- > Follow the instructions on the oil spray can and on the packaging.

Lubrication

With W&H Assistina

- > Follow the instructions in the Assistina Instructions for use.

Test after lubrication



- > Direct the medical device downwards.
- > Operate the medical device so that excess oil can escape.



Pack the medical device and the accessories in sterilization packages that meet the following requirements:

- > The sterilization package must meet the applicable standards in respect of quality and use and must be suitable for the sterilization method.
- > The sterilization package must be large enough for the sterilization goods.
- > The filled sterilization package must not be under tension.



W&H recommends sterilization according to EN 13060, EN 285 or ANSI/AAMI ST55.



- > Read the notes, follow the instructions and heed the warnings provided by the manufacturers of steam sterilizers.
- > The program selected must be suitable for the medical device.



- > Pull off the spray clip and the coolant hose from the medical device before sterilizing.
- > Sterilize the spray clip / coolant hose and the medical device.

Recommended sterilization procedures

- > “Dynamic-air-removal prevacuum cycle” (type B) / “Steam-flush pressure-pulse cycle” (type S)*/**
134°C (273°F) for at least 3 minutes, 132°C (270°F) for at least 4 minutes
- > “Gravity-displacement cycle” (type N)**
121°C (250°F) for at least 30 minutes
- > Maximum sterilization temperature 135°C (275°F)



Evidence of the medical device's basic suitability for effective sterilization was provided by an independent test laboratory using the LISA 517 B17L* steam sterilizer (W&H Sterilization S.r.l., Brusaporto (BG)), the Systec VE-150* steam sterilizer (Systec) and the CertoClav MultiControl MC2-S09S273** steam sterilizer (CertoClav GmbH, Traun).

“Dynamic-air-removal prevacuum cycle” (type B): 134°C (273°F) – 3 minutes*, 132°C (270 °F) – 4 minutes*/**
“Steam-flush pressure-pulse cycle” (type S): 134°C (273°F) – 3 minutes*, 132°C (270 °F) – 4 minutes*/**
“Gravity-displacement cycle” (type N): 121°C (250°F) – 30 minutes**

Drying times:

“Dynamic-air-removal prevacuum cycle” (type B): 132°C (270°F) – 30 minutes**
“Steam-flush pressure-pulse cycle” (type S): 132°C (270°F) – 30 minutes**
“Gravity-displacement cycle” (type N): 121°C (250°F) – 30 minutes**

* EN 13060, EN 285, ISO 17665

** ANSI/AAMI ST55 , ANSI/AAMI ST79



- > Store sterile goods dust-free and dry.
- > The shelf life of the sterile goods depends on the storage conditions and type of packaging.

7. Accessories, consumables, spare parts and other recommended medical devices by W&H



Use only original W&H accessories and spare parts or accessories approved by W&H.

Suppliers: W&H partners

Scan the QR code to find accessories, consumables and spare parts for this medical device.



Accessories, consumables, spare parts and other recommended medical devices by W&H

08067630 RC Spray kit

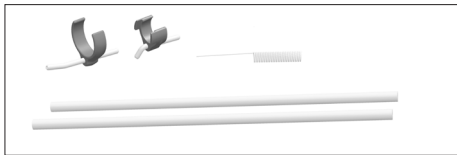

04860700 RC-E Spray kit

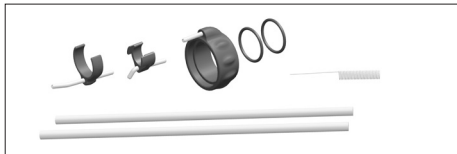

Spray kit

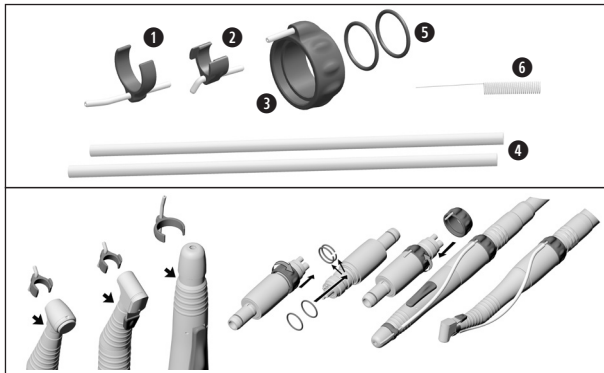

- ① Sprayclip RC-43
- ② Sprayclip RC-56, RC-58
- ③ Spray connection ring
- ④ 2 x coolant hose
- ⑤ 2 x O-ring
- ⑥ Nozzle cleaner

> Perform a test run.



> Repeat the complete hygiene and maintenance process.

8. Technical data

		RC-58 / RC-56	RC-43
Motor coupling		ISO 3964	
Maximum rated speed	(min ⁻¹)	25.000	
Transmission ratio		1:1	
Rotary instrument ISO 1797	(∅ mm)	2.35	
Length approved by W&H	(mm)	34*	50*
Min. chuck length	(mm)	engaging	engaging
Spray flow rate RC-E	ISO 14457 (ml/min)	> 50	
Recommended water pressure RC-E	(bar / psi)	0.5 – 2 / 7.3 – 29	



- * When using longer rotary instruments the user must ensure by correct selection of the operating conditions, that there is no danger to the user, patient or third parties.
For safe use, follow the respective manufacturer's instructions regarding maximum speed of the rotating instrument.

rpm = min⁻¹ (Revolutions per minute)



Temperature information

Temperature of the medical device on the operator side:

maximum 55°C (131°F)

Temperature of the medical device on the patient side:

maximum 50°C (122°F)

Temperature of the working part (rotary instrument):

maximum 41°C (105.8°F)

Ambient conditions

Temperature during storage and transport:

-40°C to +70°C (-40°F to +158°F)

Humidity during storage and transport:

8% to 80% (relative), non-condensing

Temperature during operation:

+10°C to +35°C (+50°F to +95°F)

Humidity during operation:

15% to 80% (relative), non-condensing

10. Disposal



Ensure that the parts are not contaminated on disposal.



Follow your local and national laws, directives, standards and guidelines for disposal.

- > Medical device

- > Packaging

Explanation of warranty terms

This medical device has been manufactured with great care by highly qualified specialists. A wide variety of tests and controls guarantee faultless operation. Please note that claims under warranty can only be validated when all the directions in the Instructions for use have been followed.

As manufacturer, W&H is liable for material or manufacturing defects within the warranty period.

In case of complaint, please contact your nearest W&H service partner.

We accept no responsibility for damage caused by incorrect handling or by repairs carried out by third parties not authorized to do so by W&H!

Claims under warranty accompanied by proof of purchase, must be sent to the vendor or to an authorized W&H service partner. The provision of service under warranty extends neither the warranty period nor any other guarantee period.

Warranty

Authorized W&H service partners

Find your nearest authorized W&H service partner at <http://wh.com>
Simply go to the menu option "Service" for full details.

Or simply scan the QR code.





W&H Dentalwerk Bürmoos GmbH

Ignaz-Glaser-Straße 53, 5111 Bürmoos, Austria

**t + 43 6274 6236-0,
office@wh.com**

**f + 43 6274 6236-55
wh.com**

**Form-Nr. 51034 AEN
Rev. 003 / 16.01.2024
Subject to alterations**