

Instructions for use

Edition USA



CE
0297



Surgical

Handpiece S-11 L
with mini LED+

Contents

Symbols	4
1. Introduction	6
2. Safety notes	9
3. Product description	13
4. Operation	14
Assembly/Removal	14
Rotary instruments.....	17
To change the rotary instrument.....	18
Test run	19
5. Hygiene and maintenance	20
General notes.....	20
Limitations on processing	22
Initial treatment at the point of use	23
Manual cleaning	24

Manual disinfection	29
Automated cleaning and disinfection	30
Drying	31
Inspection, Maintenance and Testing	32
Packaging	37
Sterilization.....	38
Storage	41
6. Servicing	42
7. Accessories, consumables, spare parts and other recommended medical devices by W&H.....	43
8. Technical data	44
9. Information on electromagnetic compatibility according to IEC/EN 60601-1-2	46
10. Disposal	49
Explanation of warranty terms	50
Authorized W&H service partners.....	51

Symbols



WARNING!
(risk of injury)



ATTENTION!
(to prevent
damage occurring)



General explanations,
without risk to
persons or objects



Do not dispose of with
domestic waste

R_x_{only}











Caution!

According to Federal law, this medical device may only be sold by or on the order of a dentist, physician or any other medical practitioner licensed by the law of the State in which he or she practices and intends to use or order the use of this medical device.



Manufacturer

Symbols

 CE marking with identification number of the Notified Body	 DataMatrix Code for product information including UDI (Unique Device Identification)	 Data structure in accordance with Health Industry Bar Code
 Catalogue number	 Thermo washer disinfectable	 Sterilizable up to the stated temperature
 Serial number	 UL Component Recognition Mark indicates compliance with Canadian and U.S. requirements	 Medical device
 Date of manufacture	 Consult Instructions for Use	

1. Introduction

Customer satisfaction has absolute priority in the W&H quality policy. This medical device has been developed, manufactured and subjected to final inspection according to legal regulations, quality and industry standards.

For your safety and the safety of your patients

Prior to initial use please read the Instructions for use. These explain how to use your medical device and guarantee a smooth and efficient operation.



Observe the safety notes.

Indications for use

Surgical treatment of dental hard tissue.

Intended part of the body

- > Mouth
- > Mouth Space

 Misuse may damage the medical device and hence cause risks and hazards for patient, user and third parties.

 **Qualifications of the user**
We have based our development and design of the medical device on the physician target group.

Responsibility of the manufacturer

The manufacturer can only accept responsibility for the safety, reliability and performance of the medical device when it is used in compliance with the following directions:

- > The medical device must be used in accordance with these Instructions for use.
- > The medical device has no components that can be repaired by the user.
- > Modifications or repairs must only be undertaken by an authorized W&H service partner (see page 51).



Skilled application

The medical device is intended only for skilled application according to the intended use as well as in compliance with the valid health and safety at work regulations, the valid accident prevention regulations and in compliance with these Instructions for use.

The medical device should be prepared for use and maintained by staff who have been trained in procedures for infection control, personal safety and patient safety.

Improper use, (e.g., through poor hygiene and maintenance), non-compliance with our instructions or the use of accessories and spare parts which are not approved by W&H, invalidates all claims under warranty and any other claims.



Any serious incident that has occurred in relation to the medical device should be reported to the manufacturer and the competent authority!

2. Safety notes



- > Before using the medical device for the first time, store it at room temperature for 24 hours.
- > The operation of the medical device is permitted only on supply units which correspond to the standards IEC 60601-1 (EN 60601-1) and IEC 60601-1-2 (EN 60601-1-2).
- > Always ensure the correct operating conditions and cooling function.
- > Always ensure that sufficient and adequate coolant is delivered and ensure adequate suction.
- > In case of coolant supply failure, the medical device must be stopped immediately.
- > Check the medical device for damage and loose parts each time before using.
- > Do not operate the medical device if it is damaged.
- > Only attach the medical device onto the motor when the micromotor is at a complete standstill.
- > Do not activate the chuck lever of the medical device during operation. This leads to detachment of the rotary instrument, damage to the chucking system and/or heating up of the medical device. Risk of burning!
- > Perform a test run each time before using.
- > Avoid overheating at the treatment site.



- > Do not touch the soft tissue with the handpiece head (risk of burning)!
- > Avoid contact between LED and soft tissue (risk of burning due to the LED heating up).
- > Do not use the medical device as a light probe.
- > Do not look directly into the LED.



The medical device is not approved for operation in potentially explosive atmospheres.



The medical device is not approved for operation in oxygen rich environment.

Risks due to electromagnetic fields



The functionality of active implantable medical devices (AIMD) (e.g. cardiac pacemaker, ICD) can be affected by electric, magnetic and electromagnetic fields.

- > Find out if the patient has active implantable medical devices (AIMD) before using the medical device and inform about the risks.
- > Do not place the applied part on the patient's body.

Hygiene and maintenance prior to initial use



- > The medical device is sealed in PE film and not sterilized when delivered.
- > The PE film and the packaging are non-sterilizable.



- > Clean, disinfect and lubricate the medical device.
- > Sterilize the medical device, the nozzle cleaner and the coolant tube.

3. Product description

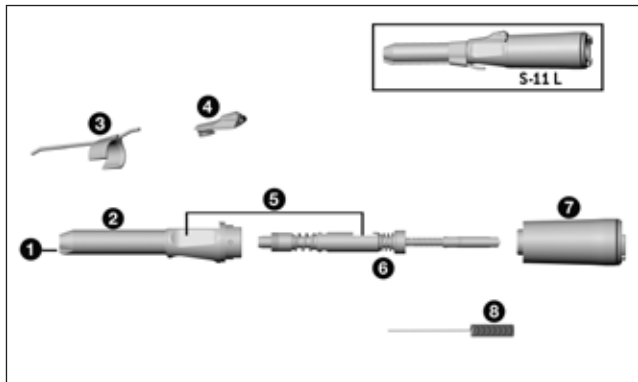

- ① LED
- ② Handpiece head*
- ③ Coolant tube (movable)
- ④ Chuck lever
- ⑤ Area of chuck lever
- ⑥ Shaft
- ⑦ Sheath*
- ⑧ Long nozzle cleaner

* Symbols on parts ② and ⑦

- ▲ Sheath open
- ↔ Direction of rotation
- ▲ Sheath locked



Do not assemble or remove the medical device during operation!



The medical device is matched to W&H electric motor EM-19 LC / EM-19 and to W&H Implantmed SI-10xx. You can only make full use of all the medical device's advantages in this combination (e.g., constant illumination at every speed).



The medical device may only be used with W&H electric motor EM-19 LC / EM-19. The user accepts sole responsibility if the medical device is used on other electric motors. The manufacturer accepts no liability.

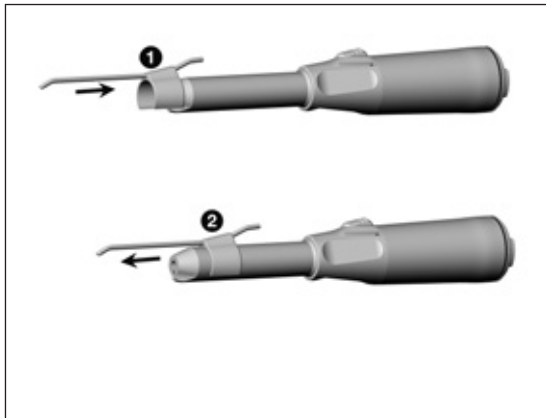

Coolant tube

- 1 Fit the coolant tube.



Check the secure hold of the coolant tube and replace it if necessary.

or

- 2 Pull off the coolant tube.

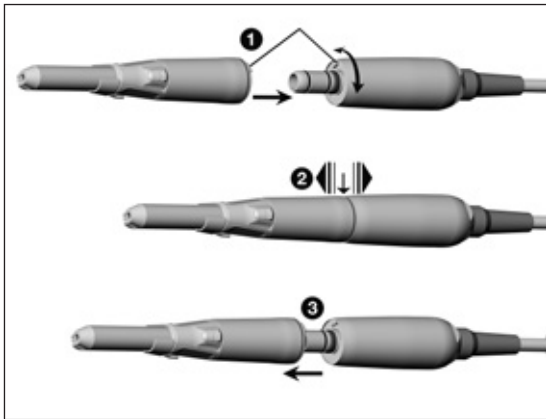

Medical device

❶ Push the medical device onto the micromotor and turn until it engages audibly.



❷ Verify full engagement.

or

❸ Remove the medical device.

Rotary instruments



- > Use only rotary instruments which are in perfect condition and pay attention to the direction of rotation of the rotary instrument. Follow the operating instructions of the manufacturer.
- > Insert the rotary instrument only when the medical device is stationary.
- > Never touch the rotary instrument while it is still rotating.
- > Do not activate the chuck lever of the medical device during operation. This leads to detachment of the rotary instrument, damage to the chucking system and/or heating up of the medical device. Risk of burning!

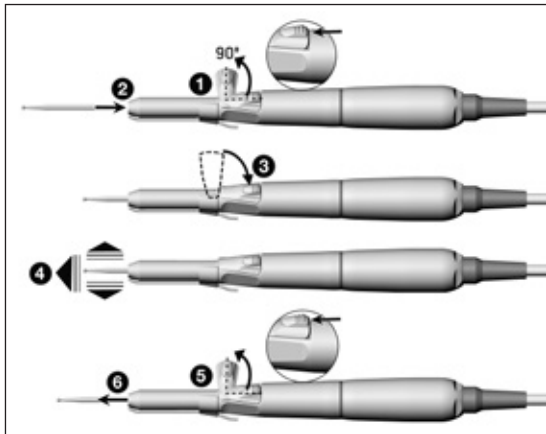

To change the rotary instrument

- 1 Unlock and swivel the chuck lever.
- 2 Insert the rotary instrument until the limit stop.
- 3 Return the chuck lever to the initial position.



- 4 Verify full engagement.

or

- 5 Unlock and swivel the chuck lever.
- 6 Remove the rotary instrument.

Test run



Do not hold the medical device at eye level.

- > Insert the rotary instrument.
- > Operate the medical device.



In the event of operating malfunctions (e.g., vibrations, unusual noise, overheating, coolant failure or leakage) **stop the medical device immediately** and contact an authorized W&H service partner.



- > Follow your local and national laws, directives, standards and guidelines for cleaning, disinfection and sterilization.



- > Wear protective clothing, safety glasses, face mask and gloves.



- > Use only oil-free, filtered compressed air with a maximum operating pressure of 3 bar for manual drying.

Cleaning agents and disinfectants



- > Read the notes, follow the instructions and heed the warnings provided by the manufacturers of cleaning agents and/or disinfectants.
- > Use only detergents which are intended for cleaning and/or disinfecting medical devices made of metal and plastic.
- > It is imperative to comply with the concentrations and exposure times specified by the manufacturer of the disinfectant.
- > Use disinfectants which have been tested and found effective by, for example: the Verbund für Angewandte Hygiene e.V. (VAH = Association for Applied Hygiene), the Österreichischen Gesellschaft für Hygiene, Mikrobiologie und Präventivmedizin (ÖGHMP = Austrian Society for Hygiene, Microbiology and Preventive Medicine), the Food and Drug Administration (FDA) or the U.S. Environmental Protection Agency (EPA).

The user is responsible for validating its process if the specified cleaning agents and disinfectants are not available.



The product lifetime and the medical device's ability to operate correctly are mainly determined by mechanical stress during use and chemical influences due to processing.

- > Send worn or damaged medical devices and/or medical devices with material changes to an authorized W&H service partner.

Processing cycles



- > We recommend a regular service for the W&H medical device after 500 processing cycles or one year.



Clean the medical device immediately after every treatment, to flush out liquid (e.g., blood, saliva etc.) and to prevent settling on the internal parts.

- > Operate the medical device for at least 10 seconds at idle speed.
- > Ensure that all outlets are rinsed out.



- > Wipe the entire surface of the medical device with disinfectant.
- > Remove the rotary instrument.
- > Remove the medical device.



Note that the disinfectant used during pre-treatment is only for personal protection and cannot replace the disinfectant step after cleaning.

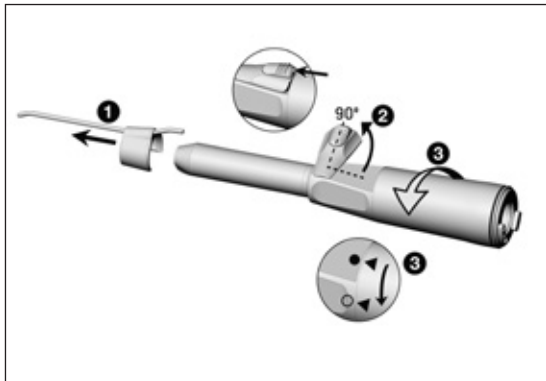

Disassembling the medical device

- 1 Pull off the coolant tube.
- 2 Unlock and swivel the chuck lever.
- 3 Twist the sheath off the handpiece head by turning it once.

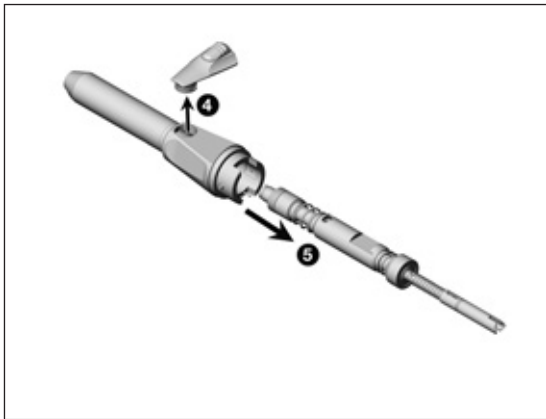

- ④ Remove the chuck lever.
- ⑤ Remove the shaft from the handpiece head.



Do not place the medical device in liquid disinfectant or in an ultrasonic bath.

- > Clean the medical device under running tap water (< 35°C / < 95°F).
- > Rinse and brush off all internal and external surfaces.
- > Move moving parts back and forth several times.
- > Remove liquid residues using compressed air.

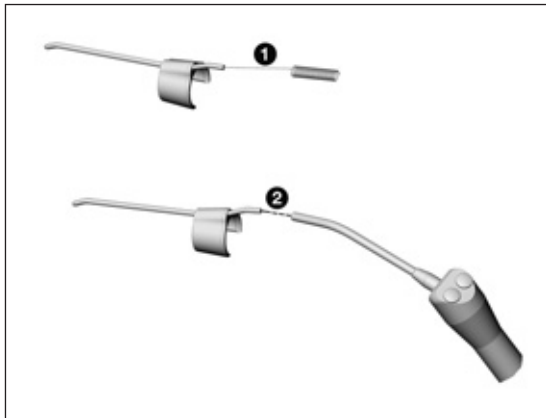

Cleaning of the coolant tube



The coolant tube and the nozzle cleaner can be cleaned in an ultrasonic bath and/or in the washer-disinfector.

- 1 Clean coolant outlets carefully with the nozzle cleaner to remove dirt and deposits.
- 2 Blow through the coolant tube using compressed air.



In case of blocked coolant outlets or coolant tubes contact an authorized W&H service partner.

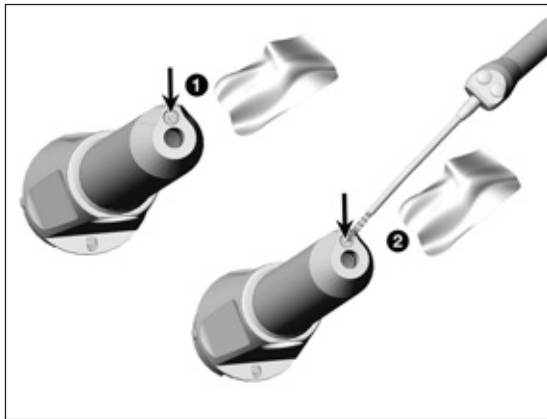

Cleaning the LED



Avoid scratching the light source!

- 1 Wash the LED with cleaning fluid and a soft cloth.
- 2 Blow the LED dry using compressed air or dry it carefully with a soft cloth.



- > Carry out a visual inspection after each cleaning process.
- > Do not use the medical device if the light source is damaged and contact an authorized W&H service partner.



> W&H recommends wiping down with disinfectant.



Evidence of the medical device's basic suitability for effective manual disinfection was provided by an independent test laboratory using the disinfectants "mikrozid® AF wipes" (Schülke & Mayr GmbH, Norderstedt) and "CaviWipes™" (Metrex).



W&H recommends automated cleaning and disinfection using a washer disinfector (WD) that is validated for medical devices and which is approved in the USA.

- > Read the notes, follow the instructions and heed the warnings provided by the manufacturers of thermal washer disinfectors, cleaning agents and/or disinfectants and thermal washer disinfector adaptors.

External coolant tubes and spray clips

Only use approved and validated adaptors for products with voids for your thermal washer disinfector.



Evidence of the medical device's basic suitability for effective automated disinfection was provided by an independent test laboratory using the »Miele PG 8582 CD« washer-disinfector (Miele & Cie. KG, Gütersloh) and the »Dr. Weigert neodisher® MediClean forte« cleaning agent (Dr. Weigert GmbH & Co. KG, Hamburg).

- > Cleaning at 55°C (131°F) – 5 minutes
- > Disinfection at 93°C (200°F) – 5 minutes



- > Ensure that the medical device is completely dry internally and externally after cleaning and disinfection.
- > Remove liquid residues using compressed air.

Inspection



- > Check the medical device after cleaning and disinfection for damage, visible residual soiling and surface changes.
- > Reprocess any medical devices that are still soiled.
- > Sterilize the reassembled medical device following cleaning, disinfection and lubrication.

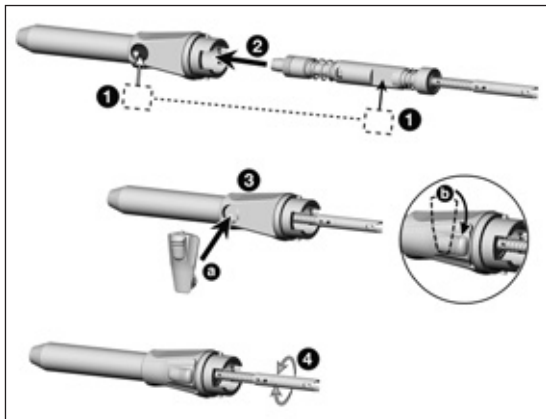

Reassembling the medical device



Reassemble the medical device following cleaning and disinfection.

- > Without coolant tube
- > Types and serial numbers must be identical

- 1 Note the positioning of the area of chuck lever.
- 2 Insert the shaft into the handpiece head.
- 3 Insert chuck lever (a) and turn it to initial position (b).
- 4 Check free running of the shaft.

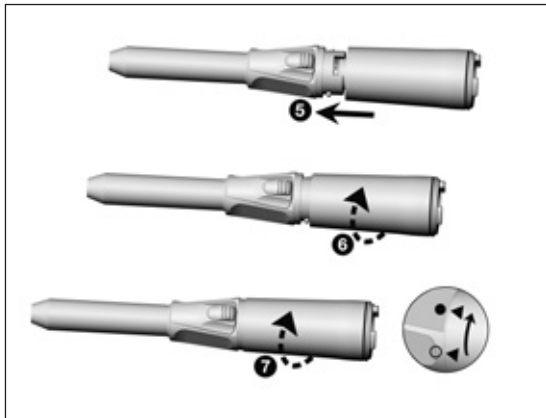

- 5 Insert the sheath onto the handpiece head.
- 6 Turn the sheath until it engages audibly.
- 7 Note the symbols and turn until locked.

Lubrication



- > Lubricate the dry medical device immediately after cleaning and/or disinfection.

Recommended lubrication cycles

- > Essential after every internal cleaning
- > Before each sterilization

With W&H Service Oil F1, MD-400

- > Follow the instructions on the oil spray can and on the packaging.
- or

With W&H Assistina

- > Follow the instructions in the Assistina Instructions for use.

Test after lubrication



- > Direct the medical device downwards.
- > Operate the medical device so that excess oil can escape.
- > Remove any oil that has escaped.
- > Excess oil may result in the medical device overheating.



Pack the medical device and the accessories in FDA cleared sterilization packages that meet the following requirements:

- > The sterilization package must meet the applicable standards in respect of quality and use and must be suitable for the sterilization method.
- > The sterilization package must be large enough for the sterilization goods.
- > The filled sterilization package must not be under tension.



W&H recommends sterilization according to ANSI/AAMI ST55, ANSI/AAMI ST79.



- > Read the notes, follow the instructions and heed the warnings provided by the manufacturers of steam sterilizers.
- > The program selected must be suitable for the medical device.



- > Pull off the coolant tube from the medical device before sterilizing.
- > Sterilize the medical device, the nozzle cleaner and the coolant tube.

Recommended sterilization procedures

- > “Dynamic-air-removal prevacuum cycle”
132°C (270°F) for at least 4 minutes
- > “Steam-flush pressure-pulse cycle”
132°C (270°F) for at least 4 minutes
- > Maximum sterilization temperature 135°C (275°F)



Evidence of the medical device's basic suitability for effective sterilization was provided by an independent test laboratory using the LISA 517 B17L steam sterilizer (W&H Sterilization S.r.l., Brusaporto (BG)) and the Systec VE-150 steam sterilizer (Systec).

“Dynamic-air-removal prevacuum cycle”:

temperature 132°C (270°F) – 4 minutes

“Steam-flush pressure-pulse cycle”:

temperature 132°C (270°F) – 4 minutes

Minimum drying times:

“Dynamic-air-removal prevacuum cycle”:

temperature 132°C (270°F) – 30 minutes

“Steam-flush pressure-pulse cycle”:

temperature 132°C (270°F) – 30 minutes

* EN 13060, EN 285, ISO 17665

** ANSI/AAMI ST55, ANSI/AAMI ST79



- > Store sterile goods dust-free and dry.
- > The shelf life of the sterile goods depends on the storage conditions and type of packaging.

6. Servicing

Repairs and returns

In the event of operating malfunctions immediately contact an authorized W&H service partner.

Repairs and maintenance work must only be undertaken by an authorized W&H service partner.



> Ensure that the medical device has been completely processed before returning it.

7. Accessories, consumables, spare parts and other recommended medical devices by W&H



Use only original W&H accessories and spare parts or accessories approved by W&H.

Supplier: W&H partners

000301xx Assistina 301 plus

30310000 Assistina TWIN (MB-302)

10940021 Service Oil F1, MD-400 (6 pcs)

02038200 Spray adaptor

00636901 Long nozzle cleaner

06879500 Coolant tube for S-11 L

8. Technical data

		S-11 L
Transmission ratio		1:1
Colour coding		blue
Permitted motor connection	[W&H]	EM-19 LC / EM-19
Rotary instruments	ISO 1797 (Ø mm)	2.35*
Permitted bur length**	[mm]	45
Minimum chucking length		until limit stop
Maximum drive speed**	[min ⁻¹]	50,000
Coolant volume	ISO 14457 [ml/min]	> 50

min⁻¹ (Revolutions per minute)

* System Stryker usable



** When using longer or shorter rotary instruments the user must ensure by correct selection of the operating conditions, that there is no danger to the user, patient or third parties.

For safe use, follow the respective manufacturer's instructions regarding maximum speed of the rotating instrument.

Temperature information



- Temperature of the medical device on the operator side: maximum 55°C (131°F)
- Temperature of the medical device on the patient side: maximum 50°C (122°F)
- Temperature of the working part (rotary instrument): maximum 41°C (105,8°F)

Ambient conditions

- Temperature during storage and transport: -40°C to +70°C (-40°F to +158°F)
- Humidity during storage and transport: 8% to 80% (relative), non-condensing
- Temperature during operation: +10°C to +35°C (+50°F to +95°F)
- Humidity during operation: 15% to 80% (relative), non-condensing

9. Information on electromagnetic compatibility according to IEC/EN 60601-1-2



Operating environment and EMC warning notes

This medical device is neither life-sustaining nor coupled to the patient. It is suitable for operation both in domestic healthcare and in facilities used for medical purposes except rooms/areas, in which EMC interference of high-intensity may occur. The customer and/or the user should assure that this medical device is set up and used in an environment of the specified type and/or in accordance with the specifications of the manufacturer.

This medical device uses RF energy only for its internal functions. Therefore, its RF emissions are very low and not likely to cause any interference in nearby electronic equipment.

No special precautions are necessary to maintain the basic safety and essential performance of this medical device.



Essential performance

This medical device has no critical functions and therefore does not have any essential performance features.



RF communication equipment

Portable RF communications equipment (including peripherals such as antenna cables and external antennas) should be used no closer than 30 cm (12 inches) to the medical device. Otherwise, degradation of the performance of this medical device could result.



W&H guarantees the compliance of the device with the EMC requirements only when used with original W&H accessories and spare parts. The use of accessories and spare parts not approved by W&H can lead to an increased emission of electromagnetic interference or to a reduced resistance against electromagnetic interference



Use of this medical device adjacent to or stacked with other equipment should be avoided because it could result in improper operation. If such use is necessary, this medical device and the other equipment should be observed to verify that they are operating normally.



The medical device is not intended for use in the vicinity of HF surgical devices.

Results of the electromagnetic tests

Requirement	Class / Test Level*)
Electromagnetic emissions	
Electromagnetic radiation disturbance (Radiated Emissions) CISPR 11/EN 55011 [30MHz - 1000MHz]	Group 1 Class B
Immunity to electromagnetic interference	
Electrostatic discharge (ESD) IEC/EN 61000-4-2	Contact discharge: ± 8 kV Air discharge: ± 15 kV
Radiated RF electromagnetic field IEC/EN 61000-4-3 [80MHz - 2,7GHz]	10 V/m
Proximity fields from RF wireless communications equipment IEC/EN 61000-4-3	385 MHz 27 V/m 450 MHz 28 V/m 710/745/780 MHz 9 V/m 810/870/930 MHz 28 V/m 1720/1845/1970 MHz 28 V/m 2450 MHz 28 V/m 5240/5500/5785 MHz 9 V/m

* There are no deviations or simplifications to IEC/EN 60601-1-2.

10. Disposal



Ensure that the parts are not contaminated on disposal.



Follow your local and national laws, directives, standards and guidelines for disposal.

- > Medical device
- > Waste electrical equipment
- > Packaging

Explanation of warranty terms

This medical device has been manufactured with great care by highly qualified specialists. A wide variety of tests and controls guarantee faultless operation. Please note that claims under warranty can only be validated when all the directions in the Instructions for use have been followed.

As manufacturer, W&H is liable for material or manufacturing defects within a warranty period of 24 months from the date of purchase. Accessories and consumables are excluded from the warranty.

We accept no responsibility for damage caused by incorrect handling or by repairs carried out by third parties not authorized to do so by W&H!

Claims under warranty accompanied by proof of purchase, must be sent to the vendor or to an authorized W&H service partner. The provision of service under warranty extends neither the warranty period nor any other guarantee period.

24 months warranty

Authorized W&H service partners

Find your nearest authorized W&H service partner at <http://wh.com>
Simply go to the menu option »Service« for full details.

Or simply scan the QR code.





W&H Dentalwerk Bürmoos GmbH

Ignaz-Glaser-Straße 53, 5111 Bürmoos, Austria

t + 43 6274 6236-0,

office@wh.com

f + 43 6274 6236-55

wh.com

Form-Nr. 50884 AAE

Rev. 004 / 06.12.2023

Subject to alterations