

Instructions for Use

Edition USA



CE
0297

implantmed^{PLUS}

SI-1010 / SI-1015 / SI-1023

Contents

Symbols	4
1. Introduction	7
2. Unpacking	9
3. Scope of delivery	10
4. Safety notes	11
5. Description	16
of front panel.....	16
of rear panel	17
of foot control	18
6. Start-up	20
7. Starting operation	22
8. Control unit operation	23
Main menu.....	23
Menue Navigation	26
Documentation with USB stick	32
ioDent® platform	34
Beacon	36
9. Error messages	37
10. Hygiene and maintenance	40
General notes	40
Limitations on processing.....	41
Initial treatment at the point of use	42
Manual cleaning.....	43
Manual disinfection	44
Automated cleaning and disinfection	45
Drying.....	46

Contents

Inspection, maintenance and testing	47
Packaging	48
Sterilization	49
Storage	51
11. Servicing	52
12. Accessories, consumables, spare parts and other recommended medical devices by W&H	54
13. Technical data	57
14. Data on electromagnetic compatibility according to IEC/EN 60601-1-2	59
15. Disposal	62
W&H course certificate	63
Explanation of warranty terms	67
Authorized W&H service partners	68

Symbols



WARNING!
(if persons could be injured)



Sterilizable up to the stated
temperature



Do not dispose of with
domestic waste



ATTENTION!
(if property could be damaged)



CE marking with identification
number of the Notified Body



DataMatrix code for product
information including UDI
(Unique Device Identification)



General explanations, without
risk to persons or property



Manufacturer



Serial number



Medical Device



Date of manufacture



Catalogue number



Thermo washer disinfectable

Symbols



Follow Instructions for Use

VA

Power consumption
(volt-ampere)

A

Electric current (ampere)



Class II equipment



Electric fuse

Hz

Frequency (hertz)



Foot control



Earth



MEDICAL – GENERAL MEDICAL EQUIPMENT AS TO ELECTRICAL SHOCK, FIRE AND MECHANICAL HAZARDS ONLY IN ACCORDANCE WITH ANSI/AAMI ES60601-1:2005/[R]2012 + A1:2012 + C1:2009/[R]2012 + A2:2010/[R]2012, ANSI/AAMI ES60601-1:2005/A2:2021, CAN/CSA-C22.2 No. 60601-1:14, CAN/CSA-C22.2 No. 60601-1:14/A2:22, IEC 80601-2-60:2019. 25UX – Control No.



Off

V

Electric voltage (volt)



On

AC

Alternating current

Symbols

rpm Revolutions per minute
(= rpm)



Temperature limitation

R_x^{only}

Caution! According to Federal law restricts this device to sale by or on the order of a physician, dentist, veterinarian or with the descriptive designation of any other practitioner licensed by the law of the State in which the practitioner practices to use or order the use of the device.



This way up



Humidity limitation



Fragile, handle with care



Data structure in accordance with Health Industry Bar Code



Keep dry





Trademark of RESY OfW GmbH for identification of recyclable transport and outer packaging of paper and cardboard



“Der Grüne Punkt” (The Green Dot) trademark of Duales System Deutschland GmbH

1. Introduction

 **For your safety and the safety of your patients**
These Instructions for use explain how to use your medical device. However, we must also warn against possible hazardous situations. Your safety, the safety of your team and, of course, the safety of your patients, are of paramount importance to us.

 Observe the safety notes.

Indication for use

Mechanical drive unit with coolant supply for transmission instruments with ISO 3964 compatible coupling system, for use in dental surgery, implantology and maxillofacial surgery (CMF) for treatment of dental hard tissue.

 Misuse may damage the medical device and hence cause risks and hazards for patients, users and third parties.

 **Qualifications of the user**
Only suitably qualified medical, technical and specialist trained staff may use the medical device.
We have based our developed and design of the medical device on the »physician« target group.

Introduction

Responsibility of the manufacturer

The manufacturer can only accept responsibility for the safety, reliability and performance of the medical device when compliance with the following instructions is ensured:

- > The medical device must be used in accordance with these Instructions for Use.
- > The medical device has no components that can be repaired by the user.
- > Modifications or repairs must only be undertaken by an authorized W&H service partner (see page 68).
- > The electrical installation at the premises must comply with the regulations laid out in IEC 60364-7-710 (“Installation of electrical equipment in rooms used for medical purposes”) or with the regulations applicable in your country.
- > Unauthorized opening of the control unit invalidates all claims under warranty and any other claims.

Improper use, unauthorized assembly, modification or repair to the medical device, non-compliance with our instructions or the use of accessories and spare parts which are not approved by W&H, invalidates all claims under warranty and any other claims.



Any serious incident that has occurred in relation to the medical device should be reported to the manufacturer and the competent authority!

2. Unpacking

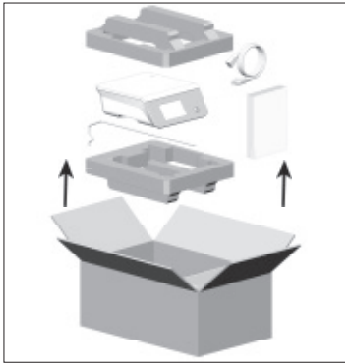

Lift out the insert with the medical device. Remove the mains cable, irrigant support, universal support and Instructions for Use.

W&H packaging is environmentally friendly and can be disposed of by industrial recycling companies. However, we recommend that you keep the original packaging.

3. Scope of delivery

Control unit		SI-1023 (230V) 30288000	SI-1015 (120V) 30289000	SI-1010 (100V) 30290000
REF 07721800	Universal support		X	
REF 04005900	Irrigant support		X	
Mains cable country-specific			X	

Optional included in set

REF 04363600	Irrigation tubing set 2.2 m (6 pcs, disposable)
REF 3028100x	EM-19 LC motor with electrical contacts and 1.8 m or 3.5 m cable
REF 30185000	EM-19 motor without electrical contacts with 1.8 m cable
REF 30264000 REF 07759700	Foot control S-NW Dongle S-NW CAN-Bus
REF 30495000 REF 08165950	Foot control S-NW3 Dongle S-NW3 CAN-Bus
REF 30285000	Foot control S-N2

4. Safety notes



- > Before using the medical device for the first time, store it at room temperature for 24 hours
- > Check the medical device for damage and loose parts each time before using.
- > Do not operate the medical device if it is damaged.
- > Check the parameter settings every time the device is restarted.
- > Perform a test run prior to every treatment.
- > The responsibility for the use and timely shutdown of the system lies with the user.
- > Ensure that it is possible to complete the operation safely should the units or instruments fail.



The medical device is not approved for operation in potentially explosive atmospheres.
The medical device is not approved for operation in oxygen rich Environment.

Safety notes



- > Use only original W&H fuses.
- > Never touch the patient and the electrical contacts on the control unit simultaneously.
- > Make sure that no computer viruses are transferred to the control unit by an external data medium (USB stick).



The connection of a USB hard drive with an external power source is not permitted.



Use the WS-75, WI-75 and SZ-75 (20:1) ratios exclusively with the contra-angle handpieces approved by W&H. Use of other contra-angle handpieces may result in deviation from the indicated torque. The user alone is therefore responsible for the above. The manufacturer does not accept any liability.



Power failure

In the event of a power failure, if the control unit is switched off, or when switching between programs, the last values set are saved and re-activated on power-up.

System failure

A total system failure does not constitute a critical fault.

Safety notes



Mains cable / Power switch

- > Only use the mains cable supplied.
- > Plug the mains cable only into an earthed power socket.
- > Set up the control unit so the power switch and the socket are easily accessible at all times.



Disconnect the control unit from the power supply in case of danger.

- > Turn off the control unit at the power switch.
- > Pull the power plug out of the socket.



Observe the manufacturer's speed and torque specifications for retaining screws for superstructures. Adjusting these retaining screws with an electric motor presents a potential risk as described above.

Note that when using or setting low speeds, the operation or run-down of rotary instruments is more difficult to detect.



Observe the manufacturer's speed and torque specifications for instruments, implants and osseodensification burs.

Safety notes



Risks due to electromagnetic fields

The functionality of active implantable medical devices (AIMD) (e.g. cardiac pacemaker, ICD) can be affected by electric, magnetic and electromagnetic fields.

- > Find out if the patient has active implantable medical devices (AIMD) before using the medical device and inform about the risks.



Follow the directions and safety notes in the Instructions for Use of the foot control, the electric motors and the transmission handpieces.

Safety notes

Coolant supply



The medical device is designed for use with physiological saline solution.



- > Always ensure correct operating conditions and that sufficient and adequate coolant is delivered.
- > Always provide sufficient coolant and ensure the appropriate suction.
- > Use only suitable coolants and follow the manufacturer's medical data and instructions.
- > Only use an irrigation tubing set approved by W&H or accessories approved by W&H.

Irrigation tubing set



- > Note the expiration date and only use disposable irrigation tubing with undamaged packaging.
- > Replace the disposable irrigation tubing immediately after every treatment.
- > Follow your local and country-specific laws, directives, standards and guidelines for disposal.

Hygiene and maintenance prior to initial use



- > Clean and disinfect the control unit, the universal support and the irrigant support.
- > Sterilize the universal support.

5. Description

of front panel

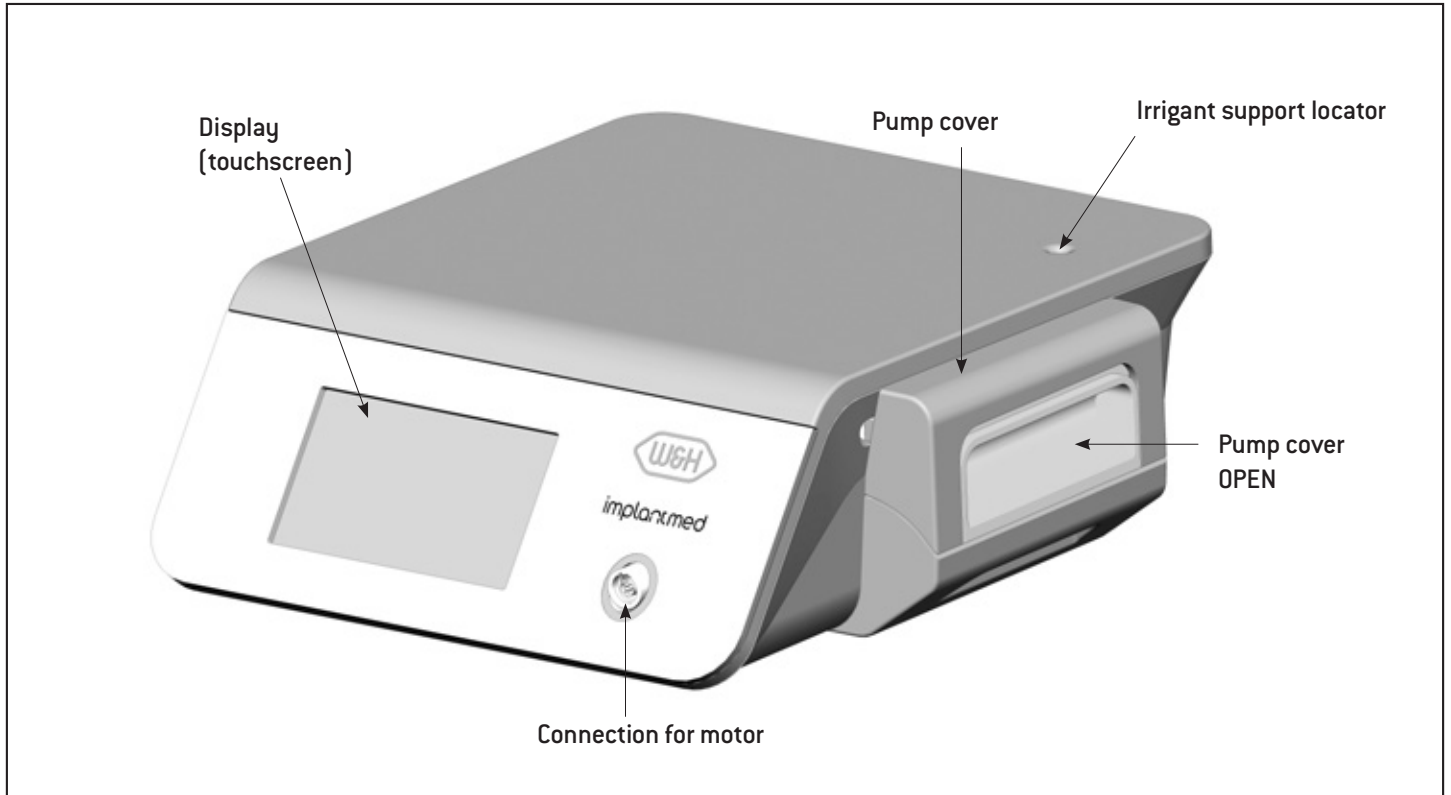

Description

of rear panel

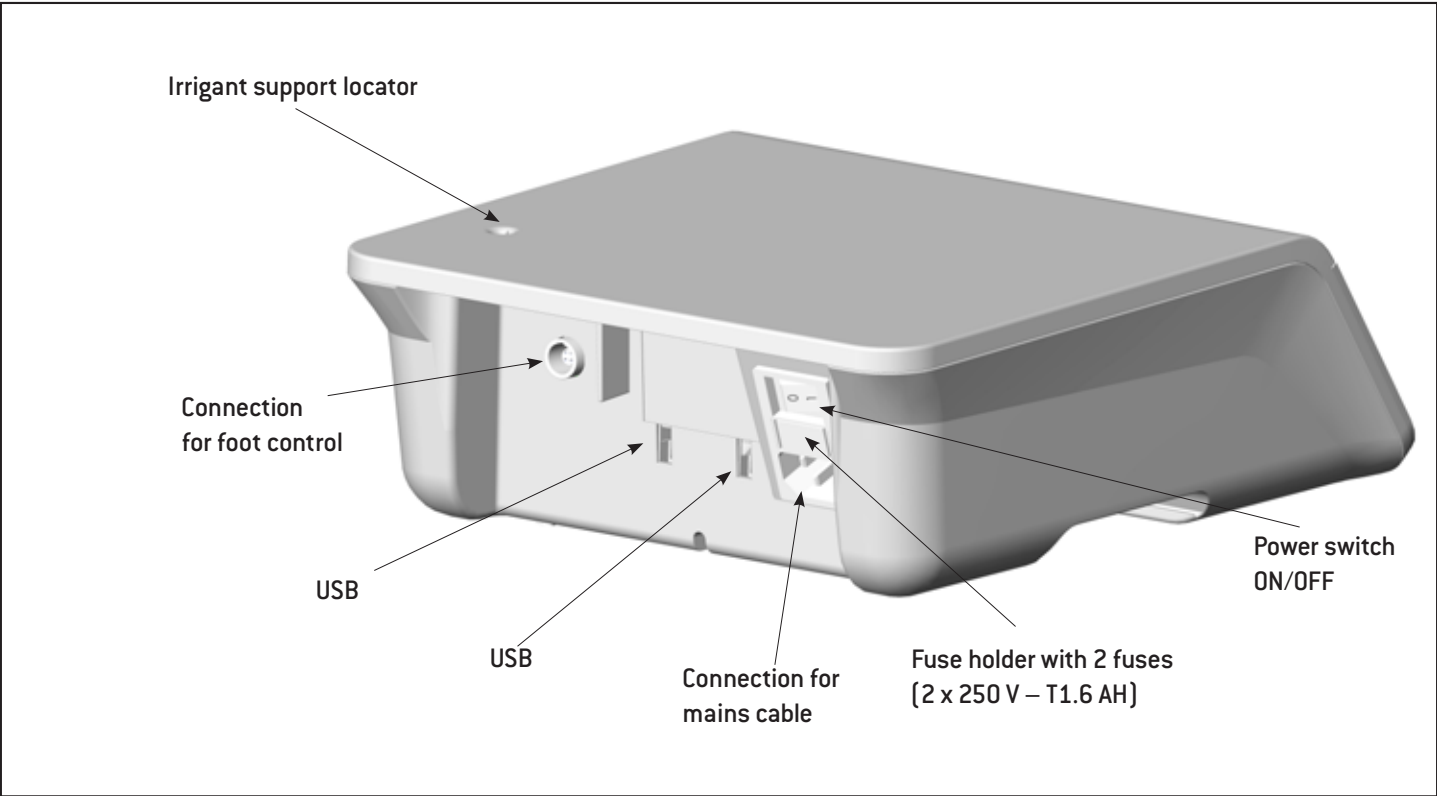

Description

of foot control

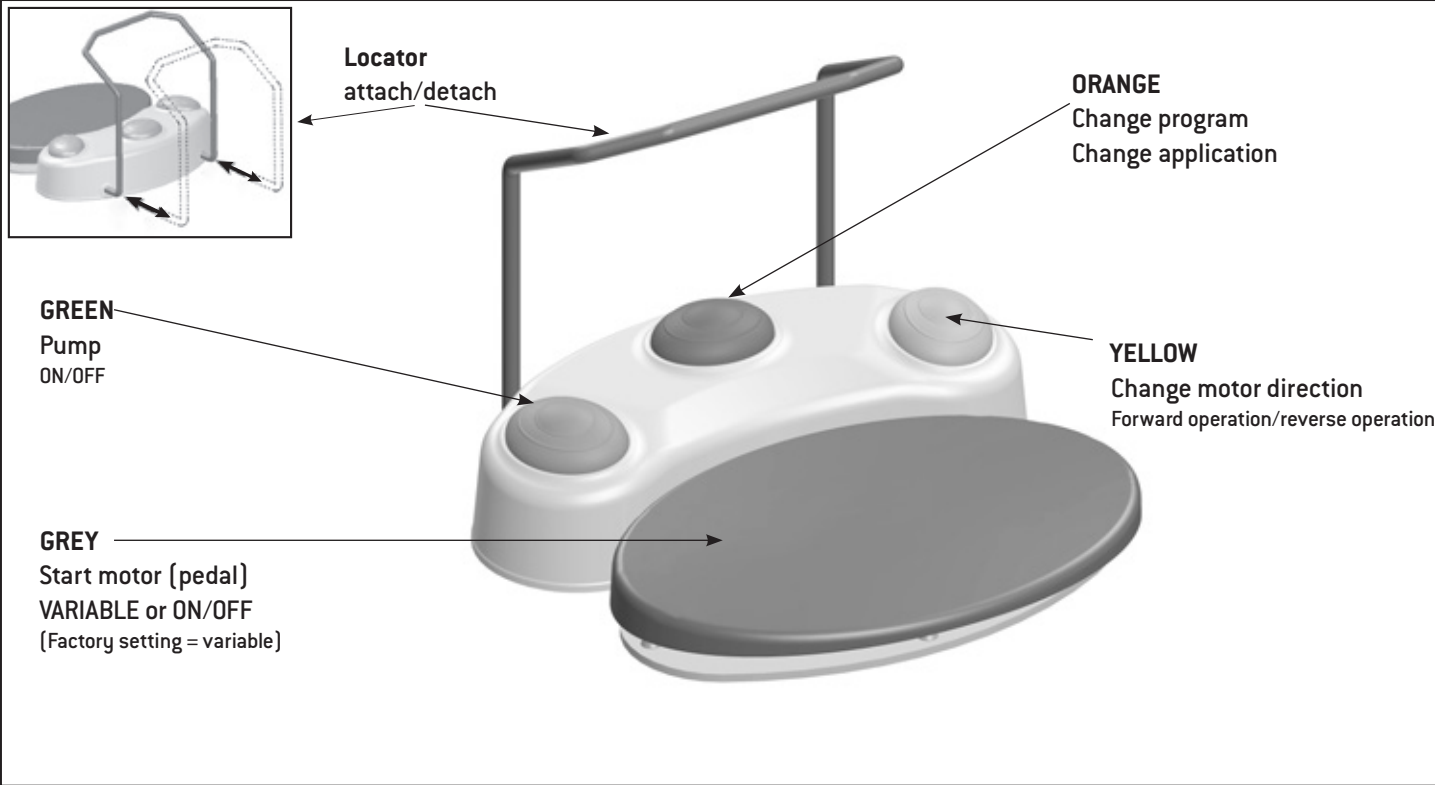

ORANGE

S-N2 / S-NW / S-NW3: Change program

Press the ORANGE button to change programs in ascending order. The motor direction is automatically set to forward operation every time the program is changed.



When changing from the last program to the first program a longer acoustic signal sounds (risk of injury).

GREEN – pump ON/OFF

Only when the motor is stationary can the pump be switched on or off by pressing the GREEN button of the foot control.

YELLOW – change motor direction

Forward operation/reverse operation

Press the YELLOW button to change from forward operation to reverse operation. A signal sounds on selection and the “Forward/reverse operation mode” symbol flashes. Before the motor starts in reverse operation, 3 audible signals are given.

6. Start-up



Place the medical device on a flat level surface.



Ensure that the medical device can be disconnected from the power supply at any time.

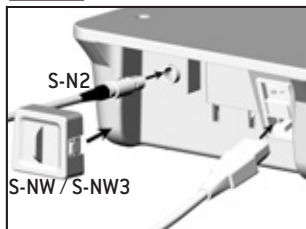

- 1** Connect the mains cable and foot control.

 Pay attention to the positioning!



- 2** Connect motor cable.

 Pay attention to the positioning!

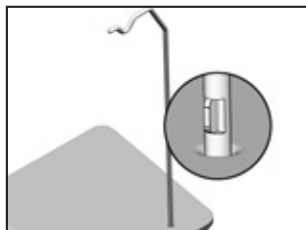

- 3** Insert the irrigant support.

 Pay attention to the positioning!
[Maximum load capacity 1.5 kg]



- 4** Attach the universal support and lock it.

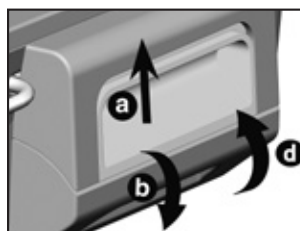

- 5** Insert the irrigation tubing.

> Open the pump cover [a,b].

> Insert the irrigation tubing [c].

> Close the pump cover [d].

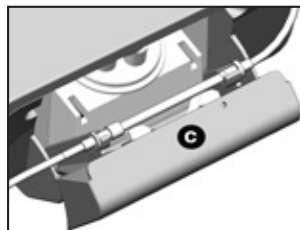

Start-up



Switching on the control unit

- 1 Plug the mains cable into an earthed power socket.



- 2 Switch on the control unit at the power switch.

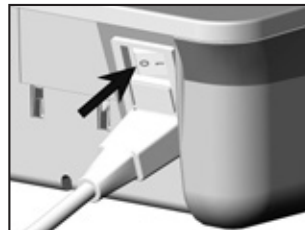

Switching off the control unit

- 1 Switch off the control unit at the power switch.



- 2 Pull the power plug out of the socket.



The touch screen must only be touched using fingers.

Using hard objects on the touch screen may scratch or damage the surface.

Setting up Implantmed

Switch on your control unit and follow the directions of the setup wizard.

The set-up wizard guides you through the various set-up stages up to the main menu:

> **Language selection**

> **Set Up Medical Device:**

Customized: Create a user

Standard: Default settings

8. Control unit operation

Main menu

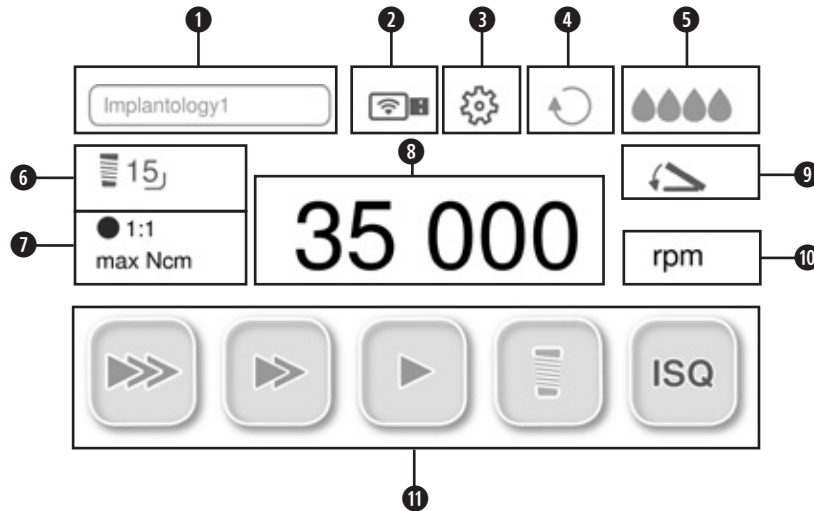

①	My favorites	⑦	Set program
②	Documentation / Wi-Fi Pairing	⑧	Set speed / torque
③	Setup	⑨	Foot control
④	Forward/reverse operation mode	⑩	Progress display mode
⑤	Set coolant volume	⑪	Programs
⑥	Tooth position		

Control unit operation

My favorites



Select drill protocol group

An activated drill protocol cannot be deleted



Edit

> Adjust factory setting of drill protocol groups.

> Create drill protocol



Copy



Rename



Activate



Delete

Control unit operation

16
● 1:1
max. 50 Ncm

Set program



Transmission

rpm Speed

At 40,000 rpm the accuracy of the set speed is $\pm 10\%$.

Ncm Torque

Adjustment range 5 – 80 Ncm with WI-75 and WS-75 only.

Adjustment range 5 – 70 Ncm with SZ-75 only.

The motor switches off automatically when the set torque is reached in forward and reverse operation modes.

The accuracy of the set torque in the 20 – 50 Ncm range for the W&H WI-75, WS-75 and SZ-75 contra-angle handpieces is $\pm 10\%$. Greater deviations may be encountered with other contra-angle handpieces.



Documentation

DOCU only appears once the documentation has been started.

rpm
{Ncm}

Progress display mode



Bar



Percent

100



Total

Control unit operation

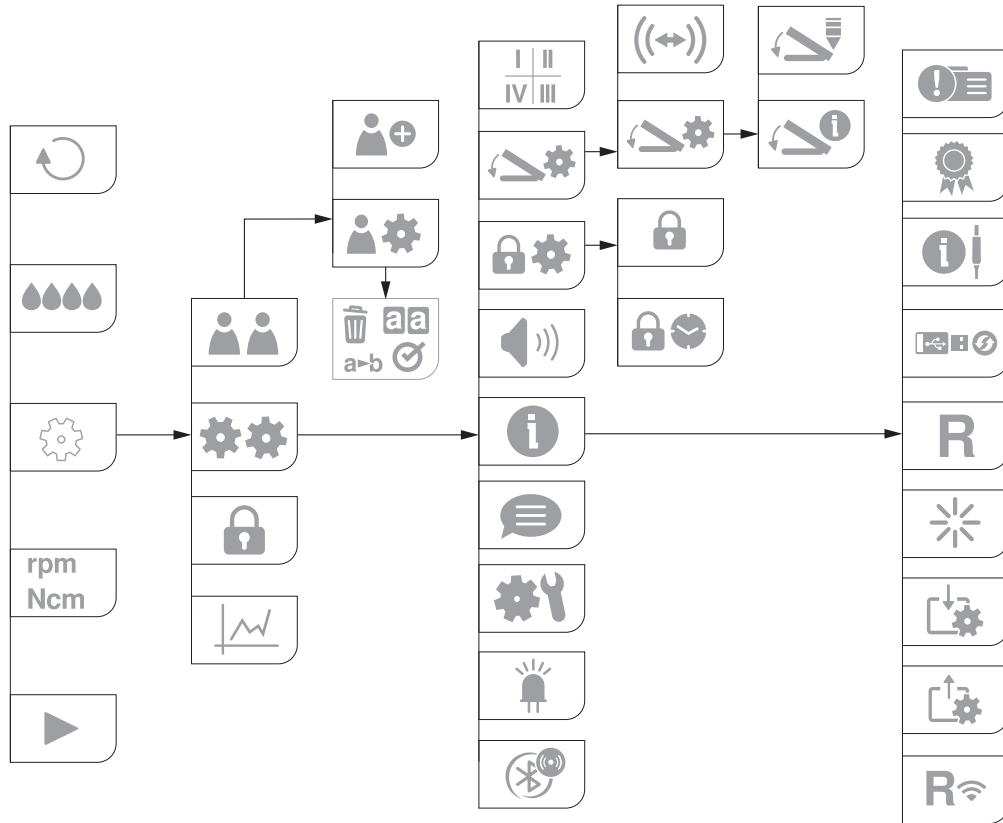
Menu Navigation



Control unit operation

 **User**
 An activated user cannot be deleted

 **Add user**

 **Manage user**
User settings: Copy, Rename, Activate, Delete

 **Foot control**

 **Pairing – S-NW / S-NW3**

 **Variable**

 **ON/OFF**

 **System**

 **Torque curve**

 **Set screen lock**
Activating / deactivating screen lock

 **Screen lock**

 **Interval**
Interval: Select time

 **LED**
Activating / deactivating LED

 **Fade-out time**
Select time

 **SOUND**
Activating/deactivating

 **Language**
Select language

Control unit operation



System check

Test run



Dental numbering system

Select dental numbering system: FDI / UNS

I–IV

FDI (Fédération Dentaire Internationale = International dental numbering system)

1–32

UNS (Universal Numbering System = American dental numbering system)



Switch between selected tooth positions (green)



Selected tooth position (black)



New position



New docu



Complete docu



Wi-Fi-dongle



Device info



Service



Licenes

GPL: GNU General Public License

LGPL: GNU Lesser General Public License



Module info



Osstell



User interface



Motor control unit

Control unit operation

 **Foot control**

 **Software update**

R  **Reset Wi-Fi pairing**

R **Reset**
Restore factory settings

 **Restart**
Control unit restarts automatically















 **Import user settings**

 **Export user settings**

 **Beacon**

 **Beacon Pairing**

Control unit operation

-  Confirm/save
-  Favorite selected
-  black = information
green = Information with selection option
-  red = error message, work cannot be continued
orange = error message, work can be continued
-  red = replace batteries
-  Foot control S-NW / S-NW3
-  Foot control S-N2
-  Drill function
-  Drill function
-  Drill function
-  Thread-cutter function
-  Implant insertion
-  ISQ Implant stability quotient measurement
-  Torque indicator function (Counter clockwise)

Thread-cutter function (chip breaker mode)



When the pedal (grey) on the foot control is pressed, the thread cutter rotates inwards until the set torque is reached. The control unit automatically switches to reverse operation when the set torque is reached. Disengaging and then re-engaging the pedal will switch the control unit back to forward operation.



If the thread cutter function is in reverse operation mode, the control unit can also start with the maximum torque.

Torque indicator function (Counter clockwise)



Three signal tones sound when the function is activated. The function starts in reverse operation as standard. A signal tone sounds and the LED on the contra-angle handpiece flashes when the set torque is reached. The maximum torque that can be set varies depending on the speed selected.

 Drill protocols, torque curves and ISQ values can only be documented in the thread-tapping function, implant insertion or ISQ measurement.

Documentation must be activated or deactivated for each program.

A USB stick is required to save the documentation.



> Never remove the USB stick while the motor is running.

> Never remove the USB stick during the measurement.

Record documentation

> Connect USB stick



Icon appears

> Enter ID

> Enter date

> Select tooth quadrant

> Select tooth

> Confirm selection



Documentation starts when the motor starts.

Further documentation

-  > Add new position
- > Start new docu
- > Complete docu



When the motor stops, a diagram appears, which is automatically saved to the USB stick.

Edit documentation

A text file (csv) and a PDF file are saved on the USB stick.
The text file can be opened in Microsoft® Excel®* for editing.
The pdf file can be opened in Adobe® Reader®**.

* Microsoft® Excel® is a registered trademark of the Microsoft® Corporation in the United States of America and/or other countries.

** Adobe® Reader® is a registered trademark of Adobe Systems Incorporated in the United States of America and/or other countries.



Follow the directions and safety notes in the Instructions for Use of the ioDent® platform.

Check the data exchange between the ioDent® platform and the medical device.



Check the transferred data for completeness and correctness.

Establishing a connection to the ioDent® platform

- > Insert the ioDent® Wi-Fi dongle
- > The connection is established



The icon appears

If the icon is green: The documentation is active

If the icon is grey: The system is connected

If the icon is yellow: There is a connection problem



When the motor stops, a diagram appears, which is automatically saved to the ioDent® platform.

 Connecting the medical device to an IT network or changing an IT network can lead to previously unidentified risks to patients, operators or third parties. The operator of the IT network is responsible for identification, analyzing, evaluating and controlling these risks. Changes to the IT-Network include changes in the IT-network configuration, connection of additional items to the IT-Network, disconnecting items from the IT- Network, update of equipment connected to the IT-Network, and upgrade of equipment connected to the IT-Network.

	Not paired device	Paired device
Device IP-address	192.168.10.1	192.168.10.x (from Gateway DHCP-Server)
Device communication port	443 (TLS/SSL)	443 (TLS/SSL)
Device subnet	255.255.255.0	255.255.255.0
Device hostname	Implantmed	Implantmed
Gateway IP	192.168.10.x	192.168.10.1

Used network layers/protocols		
Application	Application layer	https
Transport	Transport layer	SSL/TLS TCP
	Network layer	IPv4
	Data link layer	Wi-Fi (IEEE 802.11)



Follow the directions and safety notes in the Instructions for Use for the Beacon.

Establishing a connection to the Beacon

Insert the Ostell dongle.

Beacon pairing (standard)

- > Only possible in the ISQ program.
- > All Beacons connect to the medical device automatically.

Beacon pairing using the serial number



- > Enter the serial number in the system settings.
- > Only the Beacon with the entered serial number can connect to the medical device.

Deleting Beacon pairing

- > Enter 0 to delete the stored serial number.





9. Error messages









The error message disappears when it is clocked or when the pedal (grey) on the foot control is released.

Icon	Description of error	Solution
	WARNING FOOT CONTROL	<ul style="list-style-type: none">> Check plug contacts of foot control> Check the plug contacts of the dongle
	WARNING MOTOR	<ul style="list-style-type: none">> Check the plug contacts of the motor> Allow motor to cool for at least 20 minutes
	WARNING STORAGE DEVICE <ul style="list-style-type: none">> Insufficient memory available> Unknown file system> The write protection is active> Unknown storage device	<ul style="list-style-type: none">> Plug in a USB stick with sufficient memory
	WARNING OVERHEATING	<ul style="list-style-type: none">> Switch off the control unit> Allow the control unit to cool for at least 10 minutes> Switch on the control unit

Error messages

Icon	Description of error	Solution
	WARNING TIME-OUT	<ul style="list-style-type: none"> > Release the pedal (grey) on the foot control > Allow motor to cool for at least 20 minutes
	SYSTEM ERROR	<ul style="list-style-type: none"> > Switch the control unit off and back on again <p> If the error message appears again, contact an authorized W&H service partner immediately.</p>
	SYSTEM NOT PAIRED	<ul style="list-style-type: none"> > System is not paired with the gateway. > Please wait and if it occurs repeatedly contact an authorised service partner.
	WARNING OSSTELL	<ul style="list-style-type: none"> > Remove the ISQ module and then assembly or > Connect probe > Remove probe from a source of electromagnetic interference > Maintain a distance between the probe and the SmartPeg (3-5 mm) or > Switch the control unit off and back on again
	WARNING Wi-Fi CONNECTION	<ul style="list-style-type: none"> > Press the ioDent® Wi-Fi dongle symbol > Attempt to establish a connection with the Wi-Fi gateway again.

Error messages

Icon	Description of error	Solution
	WARNING CONNECTION	<ul style="list-style-type: none"> > Press the ioDent® Wi-Fi dongle symbol > Attempt to establish a connection with the ioDent® platform again.
	WARNING DATA RECEPTION	<ul style="list-style-type: none"> > Restart the data transfer on the ioDent® platform.
	WARNING TIME SYNCHRONISATION	<ul style="list-style-type: none"> > Restart the gateway > Insert the ioDent® Wi-Fi dongle again
	WARNING SYSTEM MONITORING	<ul style="list-style-type: none"> > Release the pedal (grey) on the foot control and press it again. > If the error occurs again, restart the device.
	WARNING IMPLANT DOCUMENTATION	<ul style="list-style-type: none"> > Maximum number of implants (8) for the active documentation has been reached.
	WARNING DOCUMENTATION ACTIVE	<ul style="list-style-type: none"> > Finish the current documentation on the device before starting a new one.
	WARNING SOFTWARE UPDATE FAILED	<ul style="list-style-type: none"> > Check the update files and copy the data to the USB stick again. > Insert the USB stick again. Restart the update.

- > If the described problem cannot be resolved, the unit will need to be inspected by an authorized W&H service partner.
- > In case of a total system failure, switch the control unit off and on again.



Follow your local and national laws, directives, standards and guidelines for cleaning, disinfection and sterilization.



Wear protective clothing, safety glasses, face mask and gloves.



Use only oil-free, filtered compressed air with a maximum operating pressure of 3 bar for manual drying.



Cleaning agents and disinfectants

- > Read the notes, follow the instructions and heed the warnings provided by the manufacturers of cleaning agents and/or disinfectants.
- > Use only detergents which are intended for cleaning and/or disinfecting medical devices made of metal and plastic. Manual cleaning agent: “LUMINOX®” (Alconox), disinfectant: “CaviWipes™” (Metrex)
- > It is imperative to comply with the concentrations and exposure times specified by the manufacturer of the disinfectant.
- > Use disinfectants which have been tested and found effective by the Food and Drug Administration (FDA) or the U.S. Environmental Protection Agency (EPA).



The product lifetime and the medical device's ability to operate correctly are mainly determined by mechanical stress during use and chemical influences due to processing.

Send worn or damaged medical devices and/or medical devices with material changes to an authorized W&H service partner.



Processing cycles

We recommend a regular service for the W&H universal support after 250 processing cycles.



- > Clean the medical device immediately after every treatment.
- > Wipe the control unit, the universal support and the irrigant support with disinfectant.
Manual cleaning agent: "LUMINOX®" (Alconox), disinfectant: "CaviWipes™" (Metrex)

- 1 Disconnect the motor with cable, foot control and power supply from the control unit.
Check for any damage on the outer surface of each component.
- 2 Lightly wipe all external surfaces of the control unit with a soft, lint-free cloth moistened with a neutral detergent for medical devices according to the manufacturer's instruction.
- 3 Use a clean cloth moistened with disinfectant and wipe all surfaces. Make sure all surfaces remain visibly wet at room temperature for at least the minimum time specified in the instructions for use supplied by the disinfectant manufacturer.



W&H recommends wiping down with disinfectant "CaviWipes™" (Metrex) (intermediate level).

Note that the disinfectant used during pre-treatment is only for personal protection and cannot replace the disinfectant step after cleaning.

Universal support / Irrigant support



Do not immerse the medical product in liquid disinfectant or in an ultrasonic bath.

Universal support / Irrigant support

- > Clean the universal support and the irrigant support under running tap water (< 35°C / < 95°F).
- > Rinse and brush off all external surfaces.
- > Remove liquid residues using compressed air.

Control unit



Do not immerse the medical device in water or clean it under running water.

- > Lightly wipe all external surfaces of the control unit and foot control with a soft, lint-free cloth moistened with a neutral detergent for medical devices. Clean surfaces until all visible soil is removed.
- > Remove the detergent from all surfaces using a lint-free cloth moistened with distilled water, deionized water, or demineralized water.



Evidence of the medical device's basic suitability for effective manual cleaning was provided by an independent test laboratory using the cleaning agent "LUMINOX®" (Alconox).

Evidence of the medical device's basic suitability for effective manual cleaning was provided by an independent test laboratory using tap water < 35°C and towels/cloth „WIPEX® WET DESI premium“ (NORDVLIES GmbH, Bargteheide).

Control unit / Universal support / Irrigant support



W&H recommends wipe-down disinfection.



After removing all visible soil, use a clean cloth moistened with disinfectant and wipe all surfaces. Make sure all surfaces remain visibly wet at room temperature for at least the minimum time specified in the instructions for use supplied by the disinfectant manufacturer.

Evidence of the basic suitability of the control unit, universal support and the stand for effective manual disinfection (intermediate level) was provided by an independent test laboratory using the disinfectant “CaviWipes™” (Metrex).

Universal support / Irrigant support



W&H recommends automated cleaning and disinfection using a washer-disinfector (WD).
Read the notes, follow the instructions and heed the warnings provided by the manufacturers of washer-disinfectors, cleaning agents and/or disinfectants.



The control unit is not approved for automated cleaning and disinfection.



Evidence of the basic suitability of the universal support and the irrigant support for effective automated disinfection was provided by an independent test laboratory using the “Miele PG 8582 CD” washer-disinfector (Miele & Cie. KG, Gütersloh) and the “Dr. Weigert neodisher® MediClean forte” cleaning agent (Dr. Weigert GmbH & Co. KG, Hamburg) according to ISO 15883.

- > Cleaning at 55°C (131°F) – 5 minutes
- > Disinfection at 93°C (200°F) – 5 minutes



Universal support / Irrigant support

- > Ensure that the universal support and the stand are completely dry after cleaning and disinfection.
- > Remove liquid residues using compressed air.

Inspection – Universal support / Irrigant support



- > Check the universal support and the irrigant support after cleaning and disinfection for damage, visible residual soiling and surface changes.
- > Reprocess the universal support and irrigant support that are still soiled.
- > Sterilize the universal support following cleaning and disinfection.

Universal support



Pack the universal support in FDA sterilization packages that meet the following requirements:

- > The sterilization package must meet the applicable standards in respect of quality and use and must be suitable for the sterilization method.
- > The sterilization package must be large enough for the sterilization goods.
- > The filled sterilization package must not be under tension.

Universal support



W&H recommends sterilization according to ANSI/AAMI ST55, ANSI/AAMI ST79.



- > Read the notes, follow the instructions and heed the warnings provided by the manufacturers of steam sterilizers.
- > The program selected must be suitable for the universal support.

Recommended sterilization procedures

- > “Dynamic-air-removal prevacuum cycle”
132°C (270°F) for at least 4 minutes
- > “Steam-flush pressure-pulse cycle”
132°C (270°F) for at least 4 minutes
- > Maximum sterilization temperature 135°C (275°F)

 Evidence of the basic suitability of the universal support for effective sterilization was provided by an independent test laboratory using the LISA 517 B17L* steam sterilizer (W&H Sterilization S.r.l., Brusaporto (BG)), the Systec VE-150* steam sterilizer (Systec) and the CertoClav MultiControl MC2-S09S273** steam sterilizer (CertoClav GmbH, Traun).

“Dynamic-air-removal cycle”: 132°C (270°F) – 4 minutes*/**

“Gravity-displacement cycle”: 121°C (250°F) – 30 minutes**

Minimum drying times:

“Dynamic-air-removal cycle”: 132°C (270°F) – 30 minutes**

“Gravity-displacement cycle”: 121°C (250°F) – 30 minutes**

ISO 17665

ANSI/AAMI ST55, ANSI/AAMI ST79

Universal support



- > Store sterile goods dust-free and dry.
- > The shelf life of the sterile goods depends on the storage conditions and type of packaging.

11. Servicing



Periodic inspection

Regular periodic inspection of the function and safety of the medical device is necessary and should be carried out at least once every three years, unless shorter intervals are prescribed by law.

The periodic inspection covers the complete medical device and must only be performed by an authorized service partner.

Servicing

Repairs and returns

In the event of operating malfunctions immediately contact an authorized W&H service partner.
Repairs and maintenance work must only be undertaken by an authorized W&H service partner.



Ensure that the medical device has been completely processed before returning it.



Always return equipment in the original packaging.

12. Accessories, consumables, spare parts and other recommended medical devices by W&H



Use only original W&H accessories and spare parts or accessories approved by W&H.

Suppliers: W&H partners (Link: <https://www.wh.com>)

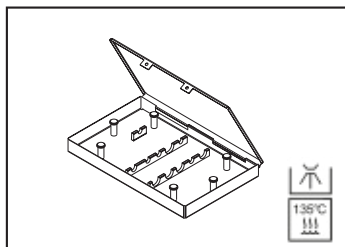

04013500

Cassette

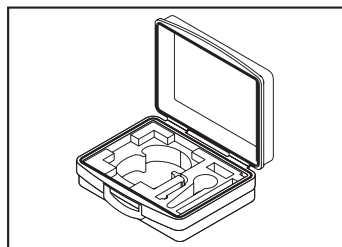

07962790

Transportation case



07721800

Universal support

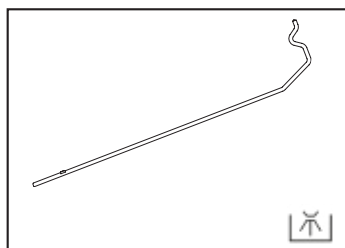

04005900

Irrigant support

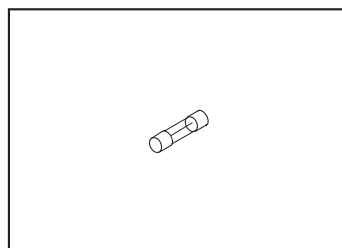

06352200

Fuse (250 V - T1.6AH)

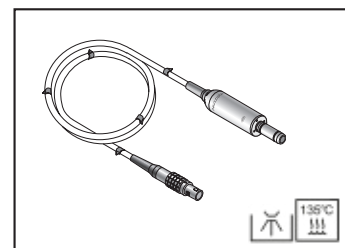

3028100x

EM-19 LC motor with electrical contacts and 1.8 m or 3.5 m cable

Accessories, consumables, spare parts and other recommended medical devices by W&H

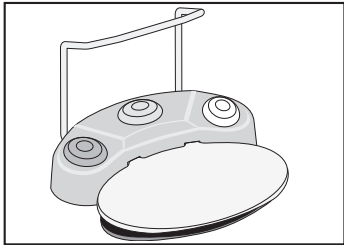

30285000

Foot control S-N2

30264000

Foot control S-NW

30495000

Foot control S-NW3

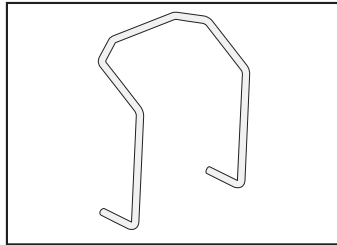

04653500

Locator for foot control

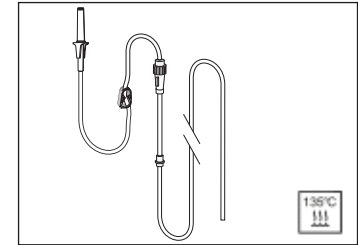

04719400

Irrigation tubing set 2.2 m

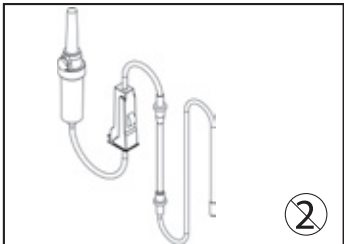

04363600

Irrigation tubing set 2.2 m (6 pcs)

04364100

Irrigation tubing set 3.8 m (6 pcs)

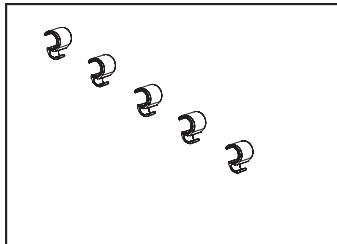

06290600

Hose clips (5 pcs)

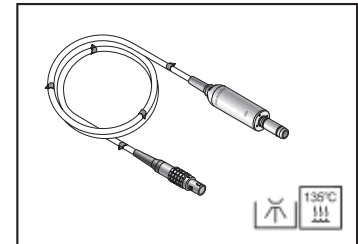

30185000

EM-19 motor without
electrical contacts
and 1.8 m cable

Accessories, consumables, spare parts and other recommended medical devices by W&H



08026120

ioDent® Wi-Fi dongle



08026150

ioDent® gateway mini

Scan the QR code to find accessories, consumables and spare parts for this medical device.



13. Technical data

Control unit	SI-1023	SI-1015	SI-1010
Mains voltage:	230 V	120 V	100 V
Permissible voltage fluctuation:	220 – 240 V	110 – 130 V	90 – 110 V
Rated current:	0.3 – 0.8 A	0.3 – 1.6 A	0.3 – 1.4 A
Maximum power consumption:	170 VA		140 VA
Frequency:	50 – 60 Hz		
Mains fuse (2 pcs):	250 V – T1.6 AH		
Maximum power output:	80 W		
Maximum torque at motor:	6.2 Ncm		
Motor speed range in the rated voltage range:	200 – 40,000 rpm		
Coolant flow rate at 100%:	min. 90 ml/min		
Dimensions in mm (height x width x depth):	100 x 262 x 291		
Weight in kg:	3.5		

Ambient conditions

Temperature during storage and transport:	-40°C to +70°C (-40°F to +158°F)
Humidity for storage and transport:	8 % to 80 % (relative), non-condensing
Temperature in operation:	+10°C to +35°C (+50°F to +95°F)
Humidity in operation:	15 % to 80 % (relative), non-condensing

Technical data

Classification according to Paragraph 6 of the General Specifications for the Safety of Medical Electrical Device according to IEC 60601-1/ANSI/AAMI ES 60601-1



Class II medical electrical device (protective earth conductor used for functional earth connection only!)



The medical device is classed as equipment without protection against the ingress of water (IPX0).

Pollution level:	2
Overvoltage category:	II
Altitude:	up to 3,000 m above sea level

14. Data on electromagnetic compatibility according to IEC/EN 60601-1-2



Operating environment and EMC warning notes

This medical device is neither life-sustaining nor coupled to the patient. It is suitable for operation both in domestic healthcare and in facilities used for medical purposes except rooms/areas, in which EMC interference of high-intensity may occur.

The customer and/or the user should assure that this medical device is set up and used in an environment of the specified type and/or in accordance with the specifications of the manufacturer. This medical device uses RF energy only for its internal functions. Therefore, its RF emissions are very low and not likely to cause any interference in nearby electronic equipment.

No special precautions are necessary to maintain the basic safety and essential performance of this medical device



Essential performance

This medical device has no critical functions and therefore does not have any essential performance features.

Data on electromagnetic compatibility according to IEC/EN 60601-1-2



RF communication equipment

Portable RF communications equipment (including peripherals such as antenna cables and external antennas) should be used no closer than 30 cm (12 inches) to the medical device. Otherwise, degradation of the performance of this medical device could result.



W&H guarantees the compliance of the device with the EMC requirements only when used with original W&H accessories and spare parts. The use of accessories and spare parts not approved by W&H can lead to an increased emission of electromagnetic interference or to a reduced resistance against electromagnetic interference.



Use of this medical device adjacent to or stacked with other equipment should be avoided because it could result in improper operation. If such use is necessary, this medical device and the other equipment should be observed to verify that they are operating normally.



The medical device is not intended for use in the vicinity of HF surgical devices.

Results of the electromagnetic tests

Requirement	Class / Test Level*	
Electromagnetic emissions		
Mains terminal disturbance voltage (Conducted Emissions) CISPR 11/EN 55011 [150 kHz – 30 MHz]	Group 1 Class B	
Electromagnetic radiation disturbance (Radiated Emissions) CISPR 11/EN 55011 [30 MHz – 1000 MHz]	Group 1 Class B	
Harmonic distortion IEC/EN 61000-3-2	Class A	
Voltage fluctuations and flicker IEC/EN 61000-3-3	–	
Immunity to electromagnetic interference		
Electrostatic discharge (ESD) IEC/EN 61000-4-2	Contact discharge: ± 2 kV, ± 4 kV, ± 6 kV, ± 8 kV Air discharge: ± 2 kV, ± 4 kV, ± 8 kV, ± 15 kV	
Radiated RF electromagnetic fields IEC/EN 61000-4-3 [80 MHz – 2,7 GHz]	10 V/m	
Proximity fields from RF wireless communications equipment IEC/EN 61000-4-3	710 / 745 / 780 / 5240 / 5500 / 5785 MHz	9 V/m
	385 MHz	27 V/m
	450 / 810 / 870 / 930 / 1720 / 1845 / 1970 / 2450 MHz	28 V/m
Electrical fast transients / bursts IEC/EN 61000-4-4	Mains supply: ± 2 kV Input and output ports: ± 1 kV	
Surges IEC/EN 61000-4-5	± 1 kV L – N	± 2 kV L – PE ± 2 kV N – PE
Conducted disturbances induced by RF fields IEC/EN 61000-4-6	3 V 6 V in ISM bands and in amateur radio bands	
Power frequency magnetic fields IEC/EN 61000-4-8	30 A/m	
Voltage dips, short interruptions and voltage variations IEC/EN 61000-4-11	0% for 0.5 cycle at 45° steps from 0°-315° 0% for 1 cycle 70% for 25/30 cycles 0% for 250/300 cycles	
Proximity magnetic fields IEC/EN 61000-4-39	30 kHz	8 A/m
	134,2 kHz	65 A/m
	13,56 MHz	7,5 A/m

* There are no deviations or simplifications to IEC/EN 60601-1-2.

15. Disposal



Ensure that the parts are not contaminated on disposal.



Follow your local and country-specific laws, directives, standards and guidelines for disposal.

- > Medical device
- > Waste electrical equipment
- > Packaging

W&H course certificate

for the user

The user has been trained to use the medical device correctly in accordance with the legal regulations (medical devices marketing regulations, medical devices act). Particular attention has been paid to the chapters on safety notes, start-up, operation, hygiene and maintenance, and service (regular inspections).

Product name	Serial number (SN)
Manufacturer with address	
Distributor with address	

Name of the user	Date of birth and/or personnel number
Hospital/dental practice/department with address	
Signature of the user	
The signature confirms that the user has been trained to use the medical device and has understood the content.	

Name of the instructor	Date of instruction
Address of the instructor	
Signature of the instructor	



W&H course certificate

for the instructor

The user has been trained to use the medical device correctly in accordance with the legal regulations (medical devices marketing regulations, medical devices act). Particular attention has been paid to the chapters on safety notes, start-up, operation, hygiene and maintenance, and service (regular inspections).

Product name	Serial number (SN)
Manufacturer with address	
Distributor with address	



Name of the user	Date of birth and/or personnel number
Hospital/dental practice/department with address	
Signature of the user	
The signature confirms that the user has been trained to use the medical device and has understood the content.	



Name of the instructor	Date of instruction
Address of the instructor	
Signature of the instructor	

Explanation of warranty terms

This W&H medical device has been manufactured with great care by highly qualified specialists. A wide variety of tests and controls guarantees faultless operation. Please note that claims under warranty can only be validated when all the directions in the Instructions for Use have been followed.

As the manufacturer, W&H is liable for material or manufacturing defects within a warranty period of 24 months from the date of purchase. Accessories and consumables are not covered by the warranty.

We accept no responsibility for damage caused by incorrect handling or by repairs carried out by third parties not authorized to do so by W&H!

Claims under warranty accompanied by proof of purchase must be sent to the vendor or to an authorized W&H service partner. The provision of service under warranty extends neither the warranty period nor any other guarantee period.

24 months warranty

Authorized W&H service partners

Find your nearest authorized W&H service partner at <http://wh.com>
Simply go to the menu option “Service” for full details.

Or simply scan the QR code.



Software version:

User interface: 01.xx.xx

MC-1.0 IP: 01.xx.xx



W&H Dentalwerk Bürmoos GmbH

Ignaz-Glaser-Straße 53, 5111 Bürmoos, Austria

t +43 6274 6236-0, f +43 6274 6236-55
office@wh.com wh.com

Form Nr. 50873 AAE
Rev. 010 / 29.10.2025
Subject to alterations